

## 'MaximumOne' Single Post Parking Lift



**ALUMINUM DRIVE ON RAMPS: Included**

### SPACE-SAVING SINGLE POST DESIGN:

Requires less garage space than two-post and four-post parking/storage lifts. Offers unrestricted access. No worries about multiple posts to scratch your car or ding your wing mirrors during entry/exit

### SUPERIOR LIFTING HEIGHT

With up to 82" of clearance on its top lock, the MaximumOne accommodates virtually any car, truck, van and SUV on the market!

### STURDY LIFTING CAPACITY:

Easily lifts most cars, trucks, vans and SUV's.

### POWER UNIT:

220v. 110v optional for 4.5 only (Derated to 4K capacity)

### POSITIVE LOCKING MECHANISM:

Precision-engineered mechanism automatically engages locks for maximum safety when lift is raised.

### ADJUSTABLE TRACK WIDTH:

You can increase or decrease the width between tracks to fit virtually any size vehicle you want!

### NON-SAG STEEL TRACKS WITH SAFETY WHEEL GUIDES:

Gives you easy access for oil changes and underbody work.

### INSTALLATION:

Mounts on standard concrete foundation using anchor bolts. Install yourself or use our nationwide professional installation service.

# MaximumOne Single Post Lift M1-4.5 and M1-6.5

M1-4.5 4500 lb. CAPACITY

M1-6.5 6500 lb. CAPACITY

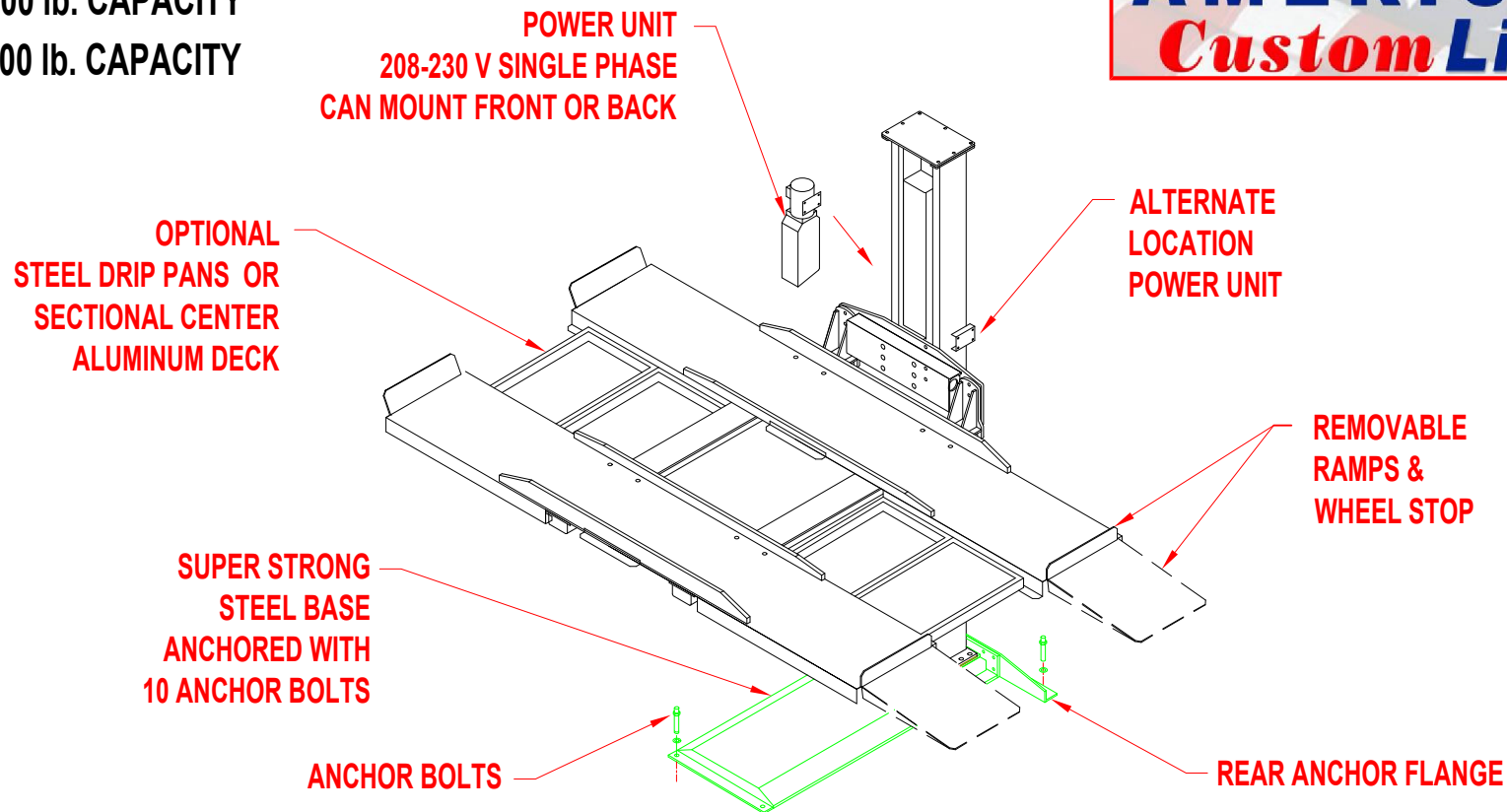

## MaximumOne Features

Superior Display Capabilities For Your Showroom, Museum, or Gallery

Out-of-the-way single post, open tracks for easy underbody viewing.

Positive Locking Mechanism \ Multiple Locking Positions: Precision-engineered mechanism automatically engages locks for maximum safety when lift is raised. Locks positions at several different heights enable you to choose the display height you want.

Adjustable Track Width: Easily lifts most cars, mini vans and medium SUV's. Easily lifts most cars, mini vans and medium SUV's.

Easy Installation: You can change the width between tracks to fit virtually any size vehicle you want.

Custom Lifts Available: Extended Height Available, Single-Point Electric Lock Release or 3 Button that allows safe and convenient push-button operation of your lift from nearby location.

Call Us Monday - Friday

7:30 AM - 4:30 PM

Toll Free 1.888.711.5438 (USA Only)

USA 619.286.5438 (Worldwide)

or email [sales@aclifts.com](mailto:sales@aclifts.com)

# MaximumOne Single Post Lift Specifications

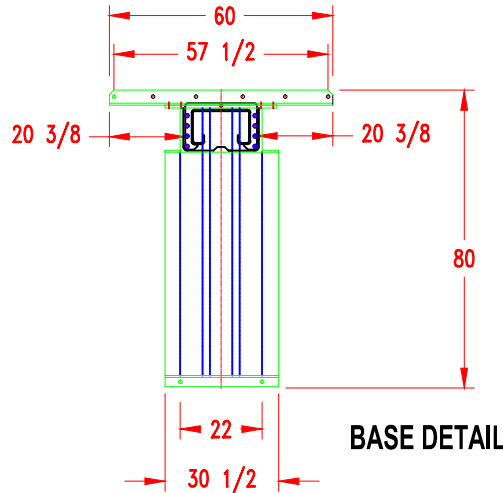
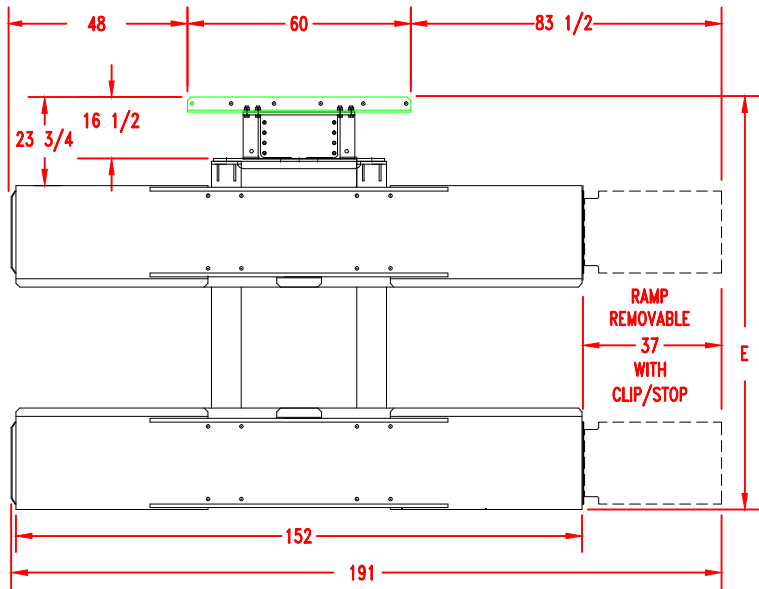

CONCRETE: 3000 PSI, 4" THICK  
REINFORCED W/ STEEL BAR, MESH

## SOLID CENTER COMPARISON

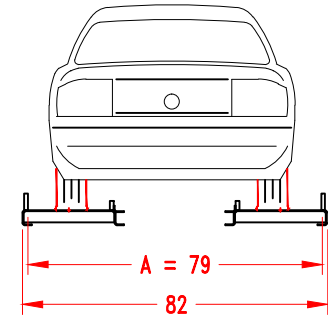

Standard: 86" arms 32" Solid Center Deck  
A = Inside 79" Outside 82"

B	35"
C	22"
D	25"
E	107"

Over all width is 106" - nominal  
Tolerance formed and weldments is plus or minus 1/4  
STACK-UP could be 107

## FRONT VIEW

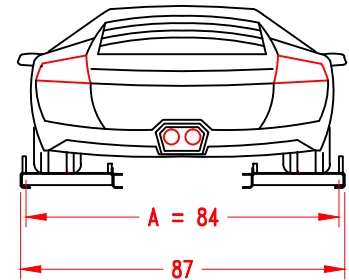
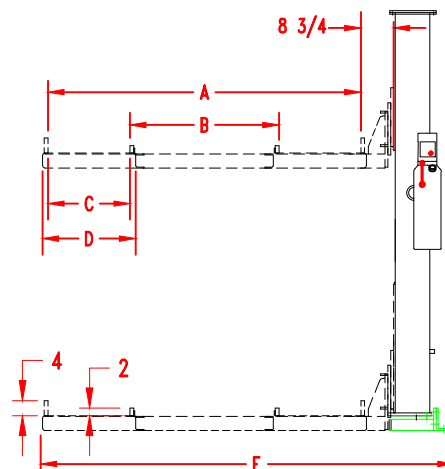
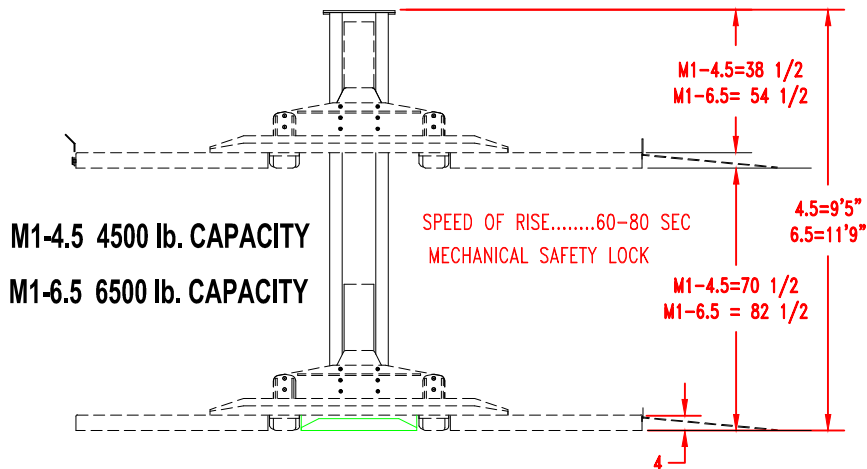

Optional: 91" arms 37" Solid Center Deck  
A = Inside 84" Outside 87"

B	40"
C	22"
D	25"
E	112"

Over all width is 110-1/2" - nominal  
Tolerance formed and weldments is plus or minus 1/4  
STACK-UP could be 112